

# Architectural and Structural Design for Blast Resistant Buildings

Paresh Govind Mirgal<sup>1</sup>, Pavan Dattatraya Tikate<sup>2</sup>, Sitaram Govindrao Suryawanshi<sup>3</sup>, S.N. Tande<sup>4</sup>

<sup>1,2,3</sup>M. Tech. Students, Department of Applied Mechanics,  
Walchand College of Engineering, Sangli, Maharashtra, India

**Abstract:** The increase in the number of terrorist attacks especially in the last few years has shown that the effect of blast loads on buildings is a serious matter that should be taken into consideration in the design process. Although these kinds of attacks are exceptional cases, man-made disasters; blast loads are in fact dynamic loads that need to be carefully calculated just like earthquake and wind loads.

The objective of this study is to shed light on blast resistant building design theories, the enhancement of building security against the effects of explosives in both architectural and structural design process and the design techniques that should be carried out. Firstly, explosives and explosion types have been explained briefly. In addition, the general aspects of explosion process have been presented to clarify the effects of explosives on buildings. To have a better understanding of explosives and characteristics of explosions will enable us to make blast resistant building design much more efficiently. Essential techniques for increasing the capacity of a building to provide protection against explosive effects is discussed both with an architectural and structural approach.

**Keywords:** Blast resistant design, blast waves, explosive effects

## 1. INTRODUCTION

Damage to the assets, loss of life and social panic are factors that have to be minimized if the threat of terrorist action cannot be stopped. Designing the structures to be fully blast resistant is not a realistic and economical option, however current engineering and architectural knowledge can enhance the new and existing buildings to mitigate the effects of an explosion.

The main target of this study is to provide guidance to engineers and architects where there is a necessity of protection against the explosions caused by detonation of high explosives. The guidance describes measures for mitigating the effects of explosions, therefore providing protection for human, structure and the valuable equipment inside. The paper includes information about explosives, blast loading parameters and enhancements for blast resistant building design both with an architectural and structural approach.

Only explosions caused by high explosives (chemical reactions) are considered within the study. High explosives are solid in form and are commonly termed condensed explosives. TNT (trinitrotoluene) is the most widely known example. There are 3 kinds of explosions which are unconfined explosions, confined explosions and explosions caused by explosives attached to the structure. [2]

Unconfined explosions can occur as an air-burst or a surface burst. In an air burst explosion, the detonation of the high explosive occurs above the ground level and intermediate amplification of the wave caused by ground reflections occurs prior to the arrival of the initial blast wave at a building (Figure 1) As the shock wave continues to propagate outwards along the ground surface, a front commonly called a Mach stem is formed by the interaction of the initial wave and the reflected wave.

However a surface burst explosion occurs when the detonation occurs close to or on the ground surface. The initial shock wave is reflected and amplified by the ground surface to produce a reflected wave. (Figure 2) Unlike the air burst, the reflected wave merges with the incident wave at the point of detonation and forms a single wave. In the majority of cases, terrorist activity occurs in built-up areas of cities, where devices are placed on or very near the ground surface.

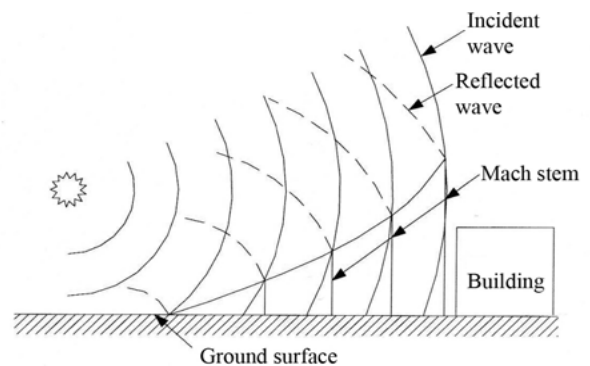

Figure 1. Air burst with ground reflections

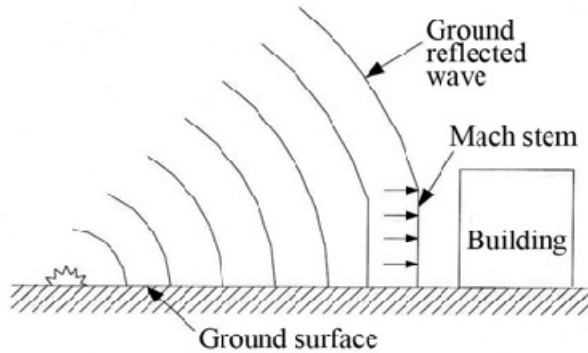

Figure 2. Surface burst

When an explosion occurs within a building, the pressures associated with the initial shock front will be high and therefore will be amplified by their reflections within the building. This type of explosion is called a confined explosion. In addition and depending on the degree of confinement, the effects of the high temperatures and accumulation of gaseous products produced by the chemical reaction involved in the explosion will cause additional pressures and increase the load duration within the structure. Depending on the extent of venting, various types of confined explosions are possible. (Figure 3)

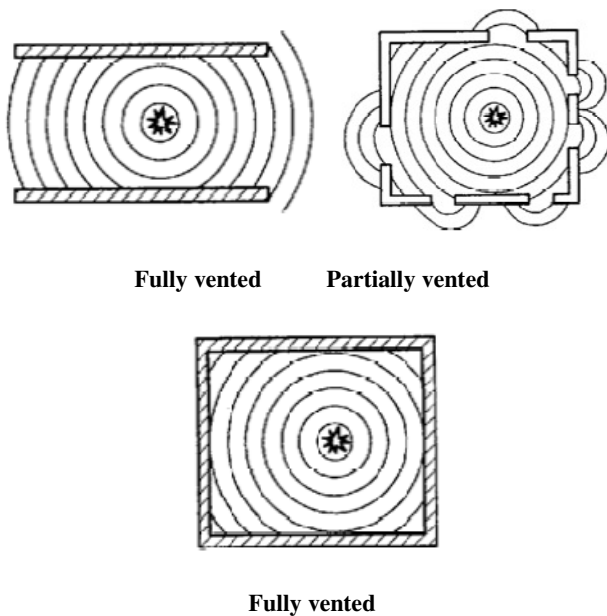

Figure 3. Fully vented, partially vented and fully confined explosions [2]

If detonating explosive is in contact with a structural component, e.g. a column, the arrival of the detonation wave at the surface of the explosive will generate intense stress waves in the material and resulting crushing of the material.

Except that an explosive in contact with a structure produces similar effects to those of unconfined or confined explosions.

There are many forms of high explosive available and as each explosive has its own detonation characteristics, the properties of each blast wave will be different. TNT is being used as the standard benchmark, where all explosions can be expressed in terms of an equivalent charge mass of TNT. The most common method of equalization is based on the ratio of an explosive's specific energy to that of TNT.

## 2. EXPLOSION PROCESS FOR HIGH EXPLOSIVES

An explosion occurs when a gas, liquid or solid material goes through a rapid chemical reaction. When the explosion occurs, gas products of the reaction are formed at a very high temperature and pressure at the source. These high pressure gasses expand rapidly into the surrounding area and a blast wave is formed. Because the gases are moving, they cause the surrounding air move as well. The damage caused by explosions is produced by the passage of compressed air in the blast wave. Blast waves propagate at supersonic speeds and reflected as they meet objects. As the blast wave continues to expand away from the source of the explosion its intensity diminishes and its effect on the objects is also reduced. However, within tunnels or enclosed passages, the blast wave will travel with very little diminution.

Close to the source of explosion the blast wave is formed and violently hot and expanding gases will exert intense loads which are difficult to quantify precisely. Once the blast wave has formed and propagating away from the source, it is convenient to separate out the different types of loading experienced by the surrounding objects.[3] Three effects have been identified in three categories. The effect rapidly compressing the surrounding air is called "air shock wave". The air pressure and air movement effect due to the accumulation of gases from the explosion chemical reactions is called "dynamic pressure" and the effect rapidly compressing the ground is called "ground shock wave".

The air shock wave produces an instantaneous increase in pressure above the ambient atmospheric pressure at a point some distance from the source. This is commonly referred to as overpressure.

As a rough approximation, 1kg of explosive produces about  $1\text{m}^3$  of gas. As this gas expands, its act on the air surrounding the source of the explosion causes it to move and increase in pressure. The movement of the displaced air may affect nearby objects and cause damage. Except for a confinement case, the effects of the dynamic pressure diminish rapidly with distance from source.

The ground shock leaving the site of an explosion consists of three principal components [3]. A compression wave which travels radially from the source; a shear wave which travels radially and comprises particle movements in a plane normal to the radial direction where the ground shock wave intersects with the surface and a surface or Raleigh wave. These waves propagate at different velocities and alternate at different frequencies.

### 3. DESIGN AND EVALUATION OF BLAST LOAD

Selection of the blast charge size  $W$  is based on the perceived risk to the design building and any buildings nearby. Various factors play a role here, such as the social and economic significance of the building, security measures that deter terrorists, and data from previous attacks on similar facilities.

The minimum standoff distance  $R$  is determined from the layout of a building's surroundings and reflects the expectation of how close to the building the design charge could explode.  $W$  and  $R$  are two necessary inputs for the scaled distance parameter  $Z = R/W^{0.33}$  that is used to determine "equivalent" design pressure impulses using published curves [8]. For greater accuracy, computer programs such as AT Blast are available.

Blast loads are applied to external building cladding if it is assumed to transfer the loads to structural elements. Where windows, doors and external walls are not expected to remain intact, blast loads also should be applied to internal structural elements. Floor slabs especially should be checked for uplift-pressure impulse. Blast loads usually are not factored and used in combination with unfactored gravity loads.

### 4. ARCHITECTURAL ASPECT OF BLAST RESISTANT BUILDING DESIGN

The target of blast resistant building design philosophy is minimizing the consequences to the structure and its inhabitants in the event of an explosion. A primary requirement is the prevention of catastrophic failure of the entire structure or large portions of it. It is also necessary to minimize the effects of blast waves transmitted into the building through openings and to minimize the effects of projectiles on the inhabitants of a building. However, in some cases blast resistant building design methods, conflicts with aesthetical concerns, accessibility variations, fire fighting regulations and the construction budget restrictions.

#### 4.1 Planning and layout

Much can be done at the planning stage of a new building to reduce potential threats and the associated risks of injury and damage. The risk of a terrorist attack, necessity of blast protection for structural and non-structural members, adequate placing of shelter areas within a building should be considered

for instance. In relation to an external threat, the priority should be to create as much stand-off distance between an external bomb and the building as possible. On congested city centers there may be little or no scope for repositioning the building, but what small stand-off there is should be secured where possible. This can be achieved by strategic location of obstructions such as bollards, trees and street furniture. Figure 5 shows a possible external layout for blast safe planning.

#### 4.2 Structural form and internal layout

Structural form is a parameter that greatly affects the blast loads on the building. Arches and domes are the types of structural forms that reduce the blast effects on the building compared with a cubicle form. The plan-shape of a building also has a significant influence on the magnitude of the blast load it is likely to experience. Complex shapes that cause multiple reflections of the blast wave should be discouraged. Projecting roofs or floors, and buildings that are U-shaped on plan are undesirable for this reason. It should be noted that single story buildings are more blast resistant compared with multi-story buildings if applicable.

Partially or fully embed buildings are quite blast resistant. These kinds of structures take the advantage of the shock absorbing property of the soil covered by. The soil provides protection in case of a nuclear explosion as well.

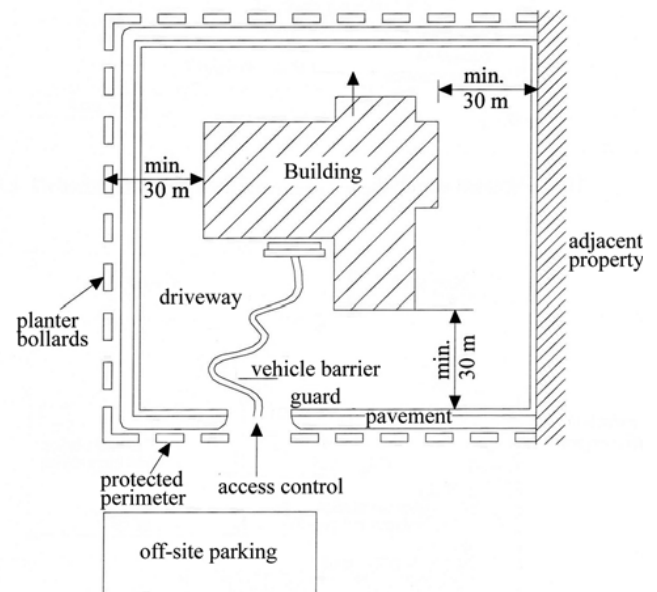

The internal layout of the building is another parameter that should be undertaken with the aim of isolating the value from the threat and should be arranged so that the highest exterior threat is separated by the greatest distance from the highest value asset. Foyer areas should be protected with reinforced concrete walls; double-dooring should be used and the doors should be arranged eccentrically within a corridor to prevent

the blast pressure entering the internals of the building. Entrance to the building should be controlled and be separated from other parts of the building by robust construction for greater physical protection. An underpass beneath or car parking below or within the building should be avoided unless access to it can be effectively controlled.

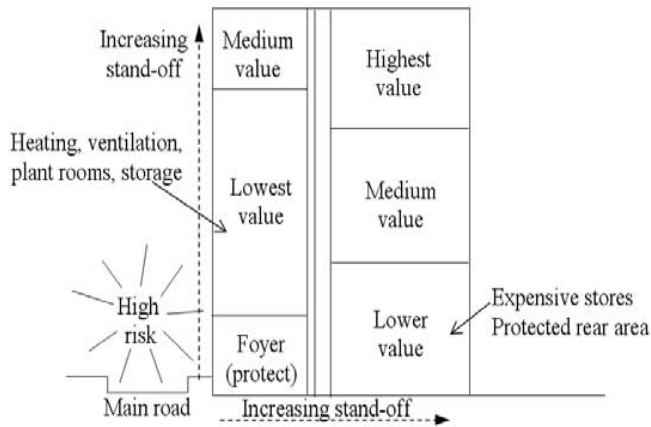

Figure 6. Internal planning of a building

A possible fire that occurs within a structure after an explosion may increase the damage catastrophically. Therefore the internal members of the building should be designed to resist the fire.

#### 4.3 Bomb shelter areas

The bomb shelter areas are specially designated within the building where vulnerability from the effects of the explosion is at a minimum and where personnel can retire in the event of a bomb threat warning. These areas must afford reasonable protection against explosions; ideally be large enough to accommodate the personnel involved and be located so as to facilitate continual access. For modern-framed buildings, shelter areas should be located away from windows, external doors, external walls and the top floors if the roof is weak. Areas surrounded by full-height concrete walls should be selected and underground car parks, gas storage tanks, areas light weight partition walls, e.g. internal corridors, toilet areas, or conference should be avoided while locating the shelter areas. Basements can sometimes be useful shelter areas, but it is important to ensure that the building does not collapse on top of them.

The functional aspects of a bomb shelter area should accommodate all the occupants of the building; provide adequate communication with outside; provide sufficient ventilation and sanitation; limit the blast pressure to less than the ear drum rupture pressure and provide alternative means of escape.

## 5. STRUCTURAL ASPECT OF BLAST RESISTANT BUILDING DESIGN

The front face of a building experiences peak overpressures due to reflection of an external blast wave. Once the initial blast wave has passed the reflected surface of the building, the peak overpressure decays to zero. As the sides and the top faces of the building are exposed to overpressures (which has no reflections and are lower than the reflected overpressures on the front face), a relieving effect of blast overpressure is experienced on the front face. The rear of the structure experiences no pressure until the blast wave has traveled the length of the structure and a compression wave has begun to move towards the centre of the rear face. Therefore the pressure built up is not instantaneous. On the other hand, there will be a time lag in the development of pressures and loads on the front and back faces. This time lag causes translational forces to act on the building in the direction of the blast wave. [4]

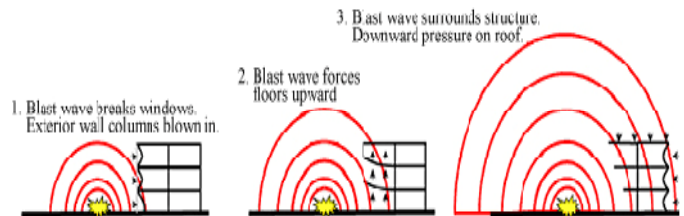

Figure 7. Sequence of air-blast effects [5]

Blast loadings are extra ordinary load cases however, during structural design, this effect should be taken into account with other loads by an adequate ratio. Similar to the static loaded case design, blast resistant dynamic design also uses the limit state design techniques which are collapse limit design and functionality limit design. In collapse limit design the target is to provide enough ductility to the building so that the explosion energy is distributed to the structure without overall collapse. For collapse limit design the behavior of structural member connections is crucial. In the case of an explosion, significant translational movement and moment occur and the loads involved should be transferred from the beams to columns. The structure doesn't collapse after the explosion however it cannot function anymore.

Functionality limit design however, requires the building to continue functionality after a possible explosion occurred. Only non-structural members like windows or cladding may need maintenance after an explosion so that they should be designed ductile enough.

When the positive phase of the shock wave is shorter than the natural vibration period of the structure, the explosion effect vanishes before the structure responds. This kind of blast loading is defined as "impulsive loading". If the positive phase

is longer than the natural vibration period of the structure, the load can be assumed constant when the structure has maximum deformation. This maximum deformation is a function of the blast loading and the structural rigidity. This kind of blast loading is defined as “quasi-static loading”. Finally, if the positive phase duration is similar to the natural vibration period of the structure, the behavior of the structure becomes quite complicated. This case can be defined as “dynamic loading”.

Frame buildings designed to resist gravity, wind loads and earthquake loads in the normal way have frequently been found to be deficient in two respects. When subjected to blast loading; the failure of beam-to-column connections and the inability of the structure to tolerate load reversal. Beam-to-column connections can be subjected to very high forces as the result of an explosion. These forces will have a horizontal component arising from the walls of the building and a vertical component arising from the differential loading on the upper and lower surfaces of floors. Providing additional robustness to these connections can be a significant enhancement.

In the connections, normal details for static loading have been found to be inadequate for blast loading. Especially for the steelwork beam-to-column connections, it is essential for the connection to bear inelastic deformations so that the moment frames could still operate after an instantaneous explosion. Figure 8 shows the side-plate connection detail in question [7]. The main features to note in the reinforced concrete connection are the use of extra links and the location of the starter bars in the connection [3] (Figure 8). These enhancements are intended to reduce the risk of collapse or the connection be damaged, possibly as a result of a load reversal on the beam.

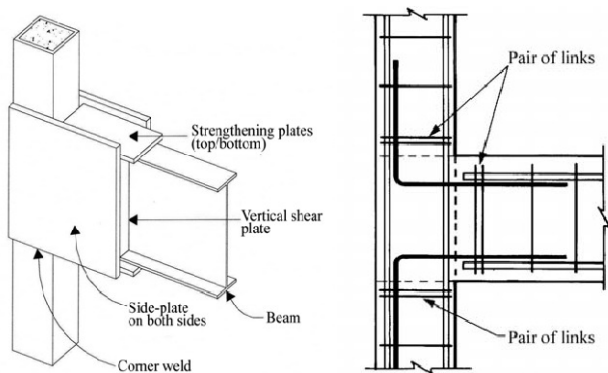

**Figure 8. Enhanced beam-to-column connection details for steelwork [7] and reinforced concrete [3]**

It is vital that in critical areas, full moment-resisting connections are made in order to ensure the load carrying capacity of structural members after an explosion. Beams acting primarily in bending may also carry significant axial load caused by the blast loading.

On the contrary, columns are predominantly loaded with axial forces under normal loading conditions, however under blast loading they may be subjected to bending. Such forces can lead to loss of load-carrying capacity of a section. In the case of an explosion, columns of a reinforced concrete structure are the most important members that should be protected. Two types of wrapping can be applied to provide this. Wrapping with steel belts or wrapping with carbon fiber-reinforced polymers (CFRP).

Cast-in-situ reinforced concrete floor slabs are the preferred option for blast resistant buildings, but it may be necessary to consider the use of precast floors in some circumstances. Precast floor units are not recommended for use at first floor where the risk from an internal explosion is greatest. Lightweight roofs and more particularly, glass roofs should be avoided and a reinforced concrete or precast concrete slab is to be preferred.

## 6. ANALYSIS METHODS USED IN BLAST RESISTANT DESIGN

Most structures are complex in behavior even under static loads, and their response to dynamic loads might include additional complications from combinations of elastic and inelastic vibration modes.

A common approach to determine the dynamic response of a structure to some specific loading is to model the structure as a system of finite structural elements and masses connected together at a discrete number of nodal points. If the force-displacement relationships are known for the individual elements, structural analysis can be used to study the behavior of the assembled structure.

It is prudent for practical design purposes to adopt approximate methods that permit rapid analysis of complex structures with reasonable accuracy. These methods usually require that both the structure and the loading be idealized to some degree.

## 7. RESULTS

The aim in blast resistant building design is to prevent the overall collapse of the building and fatal damages. Despite the fact that, the magnitude of the explosion and the loads caused by it cannot be anticipated perfectly, the most possible scenarios will let to find the necessary engineering and architectural solutions for it.

In the design process it is vital to determine the potential danger and the extent of this danger. Most importantly human safety should be provided. Moreover, to achieve functional continuity after an explosion, architectural and structural factors should be taken into account in the design process, and an optimum building plan should be put together.

This study is motivated from making buildings in a blast resistant way, pioneering to put the necessary regulations into practice for preventing human and structural loss due to the blast and other human-sourced hazards and creating a common sense about the explosions that they are possible threats in daily life. In this context, architectural and structural design of buildings should be specially considered.

During the architectural design, the behavior under extreme compression loading of the structural form, structural elements e.g. walls, flooring and secondary structural elements like cladding and glazing should be considered carefully. In conventional design, all structural elements are designed to resist the structural loads. But it should be remembered that, blast loads are unpredictable, instantaneous and extreme. Therefore, it is obvious that a building will receive less damage with a selected safety level and a blast resistant architectural design. On the other hand, these kinds of buildings will less attract the terrorist attacks.

Structural design after an environmental and architectural blast resistant design, as well stands for a great importance to prevent the overall collapse of a building. With correct selection of the structural system, well designed beam-column connections, structural elements designed adequately, moment frames that transfer sufficient load and high quality material; it's possible to build a blast resistant building. Every single member should be designed to bear the possible blast loading.

For the existing structures, retrofitting of the structural elements might be essential. Although these precautions will increase the cost of construction, to protect special buildings with terrorist attack risk like embassies, federal buildings or trade centers is unquestionable.

## REFERENCES

- [1] Koccaz Z. (2004) Blast Resistant Building Design, MSc Thesis, Istanbul Technical University, Istanbul, Turkey.
- [2] Yandzio E., Gough M. (1999). Protection of Buildings against Explosions, SCI Publication, Berkshire, U.K.
- [3] Hill J.A., Courtney M.A. (1995). The structural Engineer's Response to Explosion Damage. The Institution of Structural Engineer's Report, SETO Ltd, London.
- [4] Mays G.C., Smith P.D. (1995). Blast Effects on Buildings, Thomas Telford Publications, Heron Quay, London.
- [5] Hinman E. (2008) Blast Safety of the Building Envelope, WBDG, US
- [6] Remennikov A. (2003) Essay 1: The HSBC Bank Building Bombing: Analysis of Blast Loading, [www.safeguardingaustralia.org.au/Essays/Essay3.html](http://www.safeguardingaustralia.org.au/Essays/Essay3.html), Australia.
- [7] Punch S. (1999) Blast Design of Steel Structures to Prevent Progressive Collapse, *Structural Engineers Association Convention Proceedings*, Santa Barbara, California, U.S.A.
- [8] "Structures to Resist the Effects of Accidental Explosions," Dept. of the Army Tech. Manual, TM5-1300, Dept. of the Navy Pub. NAVFAC P-397, Dept. of the Air Force Manual, AFM 88-22, June 1969.